

LNT05

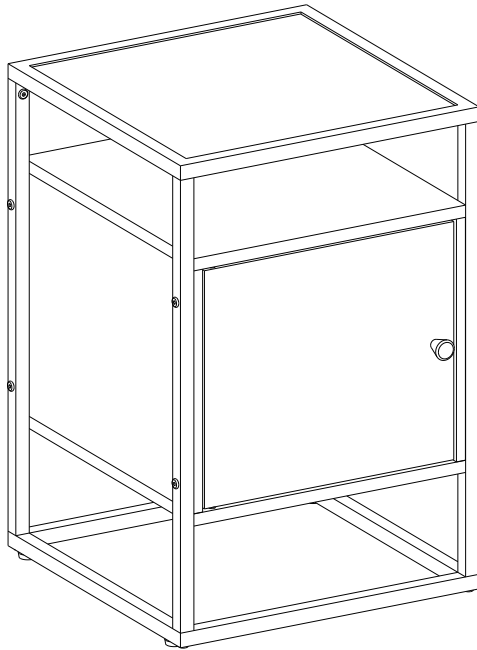

General Guidelines

- Please read the following instruction carefully and use the product accordingly.
- Please keep this manual and hand it over when you transfer the product.
- This summary may not include every detail of all variations and considered steps. Please contact us when further information and help are needed.

Notes

- It is recommended that two adults assemble the product. Please assemble this item strictly according to each step in the instructions.
- During assembly, first loosely align all screws with the corresponding pre-drilled holes and then tighten the screws one by one.
- Please use the product indoors and don't place it in a damp environment for extended periods of time to prevent mildew.
- Keep the product away from sharp objects or corrosive chemicals to prevent damage to the surface.
- Periodically inspect screw tightness while the product is in use. If necessary, re-tighten to ensure structural integrity.
- Do not hit or bump the tempered glass tabletop to prevent cracks.

Warnings

- During assembly, keep all small parts out of the reach of children. It may be fatal if swallowed or inhaled.
- Children are not allowed to climb or stand on the product to avoid personal injury caused by the product tilting or tipping over.
- Please do not use the product if there is/are defective and/or missing part/s, as this can result in damage or injury.
- To avoid the potential dangers of suffocation, please keep all parts and packaging (film, plastic bags, foam, etc.) away from babies and children.
- The maximum load capacity of the glass tabletop is 30 kg (66 lb). Please do not place overweight items on it.

Einleitung

- Bitte lesen Sie die folgende Anleitung aufmerksam durch und verwenden Sie das Produkt sachgemäß.
- Bewahren Sie diese Anleitung gut auf und händigen Sie sie bei Weitergabe des Produkts an Dritte ebenfalls mit aus.
- Aus Gründen der Übersicht können nicht alle Details zu allen Varianten und denkbaren Montagen beschrieben werden. Wenn Sie weitere Informationen und Hilfe benötigen, kontaktieren Sie uns bitte.

Hinweise

- Der Zusammenbau sollte durch zwei Erwachsene erfolgen. Bauen Sie und benutzen Sie das Produkt bitte streng nach der Anleitung auf.
- Ziehen Sie die Schrauben bitte zuerst nicht an. Nachdem Sie alle Schrauben eingesetzt haben, schrauben Sie

- sie erst vorsichtig fest.
- Dieses Produkt ist nur für den Gebrauch in Innenräumen vorgesehen. Halten Sie das Produkt nicht langfristig in einer feuchten Umgebung, um Schimmel zu vermeiden.
- Halten Sie spitze Gegenstände und ätzende Chemikalien vom Produkt fern, da diese die Oberfläche beschädigen können.
- Prüfen Sie regelmäßig den festen Sitz der Schrauben und Verbindungen, falls notwendig nachziehen.
- Gewalteinwirkungen auf die Tischoberfläche aus Hartglas wie Schläge oder Stöße können zu Rissen im Glas führen und sind daher zu vermeiden.

Warnhinweise

- Halten Sie Kinder bei der Montage fern, da Kleinteile bei Verschlucken oder Einatmen tödlich sein können.
- Um mögliche Körperverletzungen zu vermeiden, ist es Kindern verboten, auf diesem Produkt zu klettern oder damit zu spielen.
- Benutzen Sie das Produkt NICHT, wenn Teile beschädigt sind oder fehlen.
- Schützen Sie Ihre Kinder von Verpackungsteile wie Folien oder Plastikbeutel fern, da Verpackungsteile oft nicht erkennbare Gefahren bergen (z. B. Erstickungsgefahr).
- Die max. Belastbarkeit der Glas-Oberfläche beträgt 30 kg, legen Sie keine zu schweren Gegenstände auf das Produkt.

FR

Introduction

- Lisez attentivement ces instructions et utilisez votre produit d'après ce mode d'emploi.
- Conservez ces instructions. Si vous souhaitez offrir ce produit à un tiers, joignez obligatoirement ce mode d'emploi.
- Pour des raisons de clarté, les détails concernant chaque variante ou montage envisageable ne peuvent être tous décrits. Si vous souhaitez obtenir plus d'informations ou si vous rencontrez certains problèmes non traités de manière détaillée dans ces instructions, veuillez nous contacter.

Notes

- L'assemblage doit être réalisé par deux adultes en suivant scrupuleusement de ce mode d'emploi.
- Lors du montage, veuillez bien positionner toutes les vis, ensuite effectuer un serrage progressif de l'ensemble des vis.
- Ce produit est conçu pour un usage à l'intérieur, et ne doit pas être placé dans un environnement humide pendant une longue durée pour éviter les moisissures.
- Évitez tout contact avec des objets pointus et corrosifs pour éviter d'endommager ce produit.
- Nous vous invitons à vérifier régulièrement les vis qui pourraient se desserrer progressivement pendant l'utilisation, ce qui risque de provoquer les dommages causés par un renversement du produit. Veuillez donc assurer que les vis sont toujours bien serrées.
- Ne frappez pas ni cognez le verre trempé pour éviter de provoquer les fissures.

Avvertissements

- Les enfants ne sont pas autorisés à participer à l'assemblage de ce produit car il comprend de nombreuses petites pièces. L'inspiration ou l'ingestion de ces pièces présente un risque mortel.
- Ne laissez pas les enfants monter ou jouer sur ce produit pour éviter les blessures causées par le renversement.
- N'utilisez jamais ce produit dans le cas de manque ou défectuosité des pièces pour éviter le danger potentiel.
- Gardez toutes les pièces de l'emballage(films, sacs plastiques, polystyrènes, etc.) hors de la portée des enfants pour éviter les dangers potentiels (par ex. L'étouffement).
- La charge max du verre supérieur est de 30 kg, et ne dépassez pas sa limite.

IT

Linee guida generali

- Si prega di leggere attentamente le seguenti istruzioni e usare il prodotto in modo opportuno.
- Si prega di conservare questo manuale e consegnarlo quando il prodotto cambia proprietario.
- Questo riassunto potrebbe non includere ogni dettaglio di tutte le variazioni e le fasi considerate. Contattaci se hai bisogno di ulteriori informazioni e assistenza.

Note

- Si raccomandano due persone per assemblare il prodotto. Si prega di seguire attentamente i passaggi descritti.
- Non stringere completamente le viti fino a quando tutte le viti sono allineate con i fori preforati corrispondenti.
- Il prodotto è inteso per uso interno. Si prega di evitare un'esposizione prolungata ad ambienti umidi per prevenire la formazione di muffa.
- Evitare il contatto con oggetti appuntiti e sostanze chimiche corrosive per prevenire danni al prodotto.
- Controllare regolarmente le viti, potrebbero allentarsi durante l'uso. Se necessario, stringerle di nuovo per garantire stabilità e sicurezza.
- Non urtare il piano del tavolo in vetro temperato per evitare lesioni personali.

Avvertenze

- Impedire ai bambini di assemblare il prodotto. Durante l'assemblaggio, tenere le parti di piccole dimensioni fuori dalla portata dei bambini, potrebbero essere fatali se ingerite o inalate.
- Impedire ai bambini di salire in piedi, arrampicarsi o giocare sul prodotto per evitare infortuni gravi causati dalla caduta.
- Si prega di non utilizzare il prodotto in caso di parti difettose e/o mancanti, in quanto ciò può causare danni o lesioni.
- Tenere gli imballaggi di plastica fuori dalla portata dei bambini per evitare qualsiasi potenziale pericolo, come il soffocamento.
- La capacità di carico massima del piano di tavolo in vetro temperato è 30 kg. Non appoggiare oggetti oltre questo limite.

ES

Acerca del manual

- Por favor, lea detenidamente las instrucciones y respete los debidos usos del producto.
- Por favor, conserve bien este manual y en caso de cesión, no omita entregarlo junto al producto.
- Este manual podría no incluir todos los detalles de cada paso del montaje. Si necesita ayuda o información adicional, póngase en contacto con nosotros.







Notas

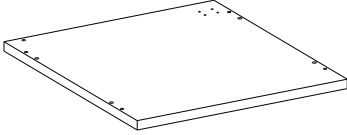
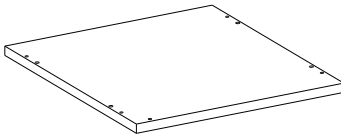
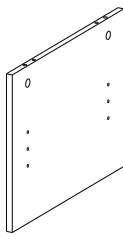
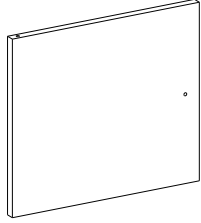
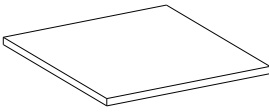
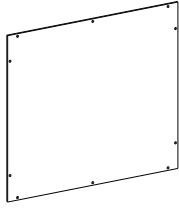
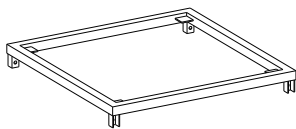
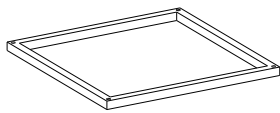

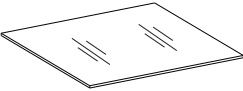

- Se recomienda que dos adultos ensamblen el producto. Por favor, ensamble el producto estrictamente de acuerdo con cada paso de las instrucciones.
- Durante el montaje, alinee primero todos los tornillos con los orificios pretaladrados correspondientes, a continuación, apriete los tornillos uno por uno.
- Por favor, use el producto en interiores y no lo coloque en un ambiente húmedo durante largos períodos de tiempo para prevenir el moho.
- Mantenga el producto alejado de objetos punzantes o productos químicos corrosivos para evitar daños en la superficie.
- Inspeccione periódicamente el ajuste de los tornillos mientras el producto esté en uso. Si es necesario, vuelva a apretar para asegurar la integridad estructural.
- No golpee la superficie de la mesa de vidrio violentamente para evitar lesiones personales.

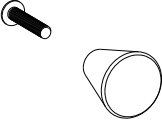

Advertencias

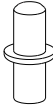
- Durante el montaje, mantenga todas las piezas pequeñas fuera del alcance de los niños. Puede ser mortal si se ingiere o inhala.
- No se permite que los niños se suban o se pisen sobre el producto para evitar lesiones personales causadas por la inclinación o vuelco del producto.
- Por favor, no utilice el producto si está defectuoso y/o le faltan piezas, ya que esto puede ocasionar daños o lesiones.
- Para evitar los peligros potenciales de asfixia, mantenga todas las piezas y embalajes (películas, bolsas de plástico y espuma, etc.) fuera del alcance de los bebés y los niños.
- La capacidad de carga máxima de cristal es de 30 kg. Por favor, no coloque artículos con sobrepeso en él.

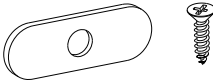
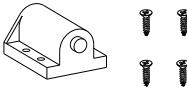
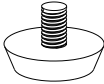
<p>A × 1</p>  A square panel with a beveled edge and small circular indentations along the perimeter.	<p>B × 1</p>  A square panel with a beveled edge and small circular indentations along the perimeter, similar to panel A.
<p>C × 2</p>  A rectangular panel with a beveled edge, small circular indentations along the perimeter, and a small '0' mark near the top edge.	<p>D × 1</p>  A rectangular panel with a beveled edge and a small circular hole near the bottom right corner.
<p>E × 1</p>  A square panel with a beveled edge.	<p>F × 1</p>  A rectangular panel with a beveled edge and small circular indentations along the perimeter.
<p>G × 1</p>  A square panel with a beveled edge and four small feet or legs attached to the corners.	<p>H × 1</p>  A square panel with a beveled edge.

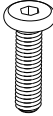
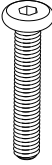
<p>I  × 4</p>	<p>J  × 1</p>
<p>1  4+1</p>	<p>2  8+2</p>
<p>3  4+1</p>	<p>4  1+1</p>
<p>5  1+1</p>	<p>6  × 1</p>

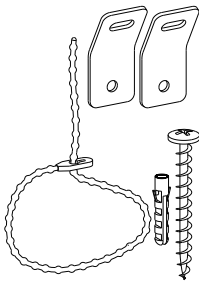
<p>7 4+1</p> 	<p>8 4+1</p> 	<p>9 10+2</p> 
<p>10 × 1</p> 	<p>11 × 1</p> 	<p>12 × 4</p> 
<p>13 4+1</p>  <p>M6 × 12 mm</p>	<p>14 8+1</p>  <p>M6 × 25 mm</p>	<p>15 4+1</p>  <p>M6 × 40 mm</p>

<p>16 4+1</p> 	<p>17 × 2</p> 	<p>18 × 1</p> 
<p>19 × 1</p> 		

1

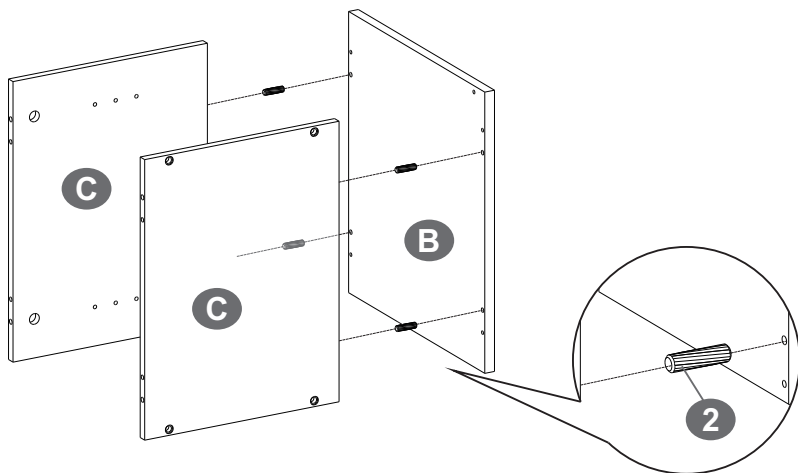

2



4PCS

2

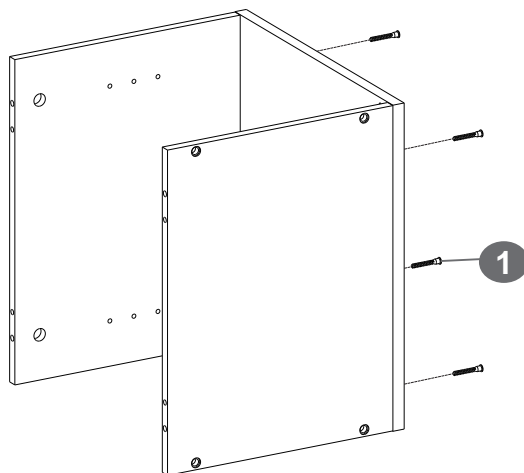

1



4PCS

3

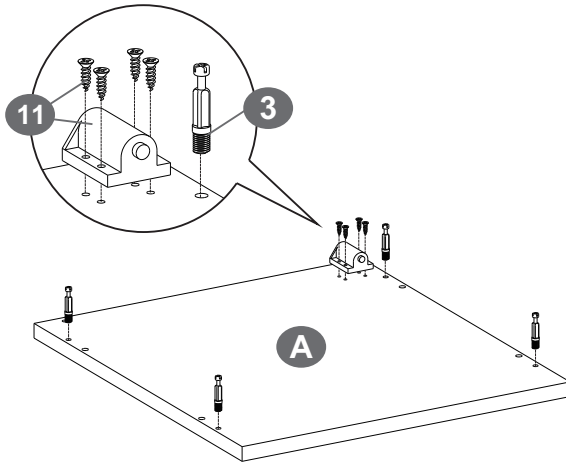

3



4PCS

4

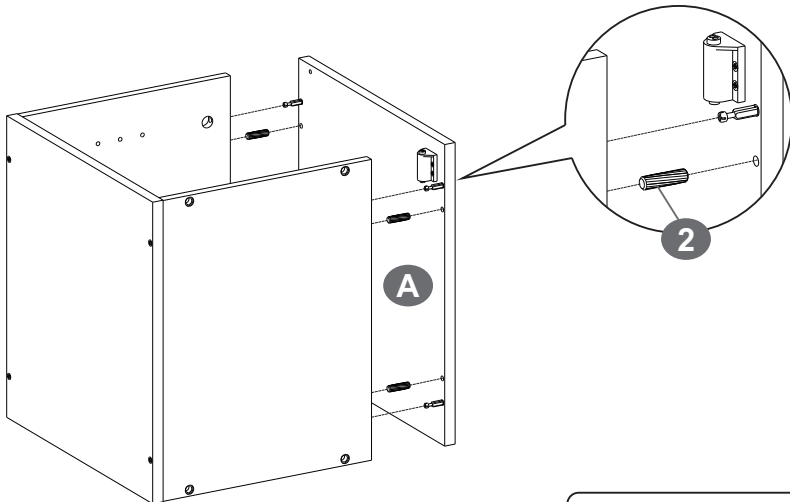

2



4PCS

5

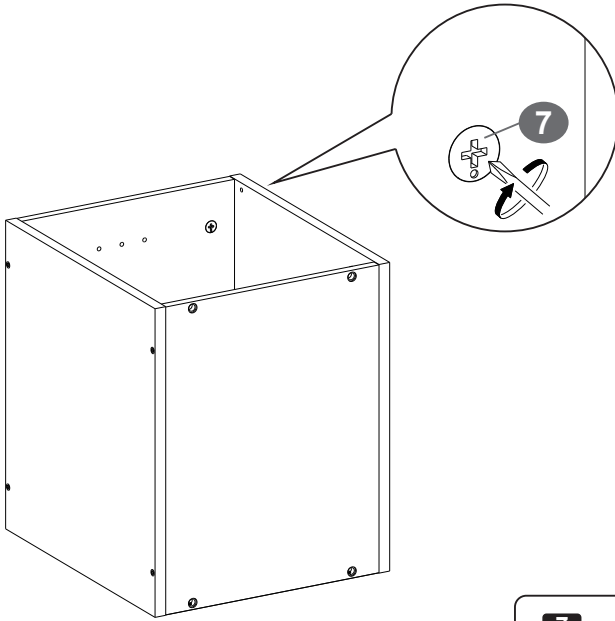

7



4PCS

6

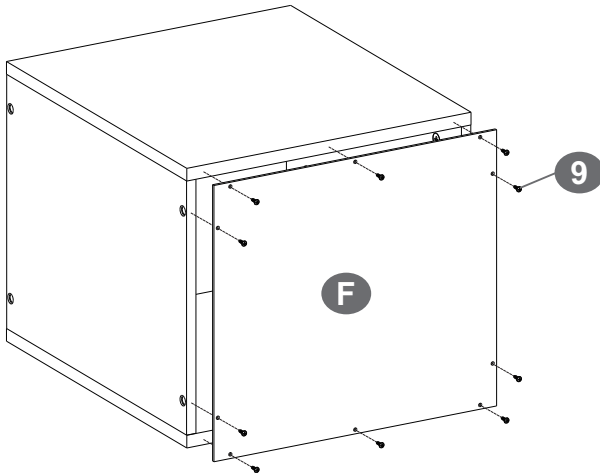

9



10PCS

7

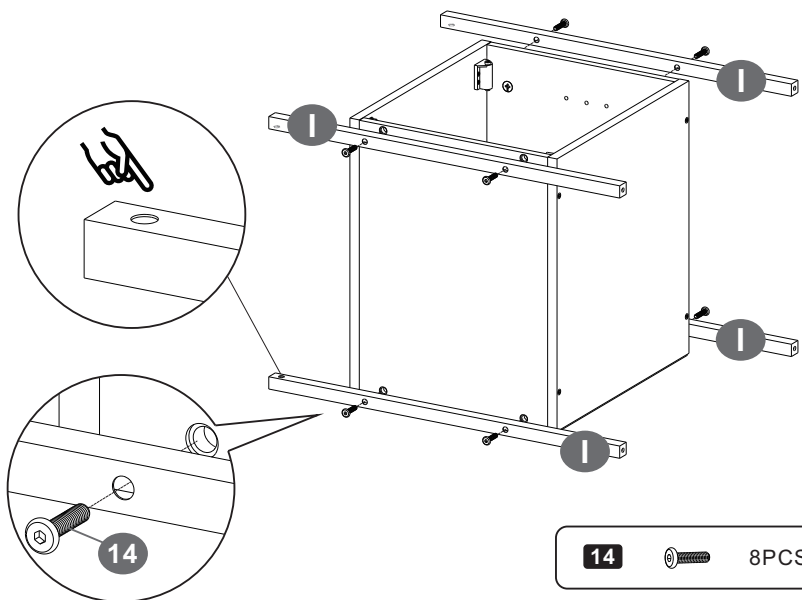

14



8PCS

8

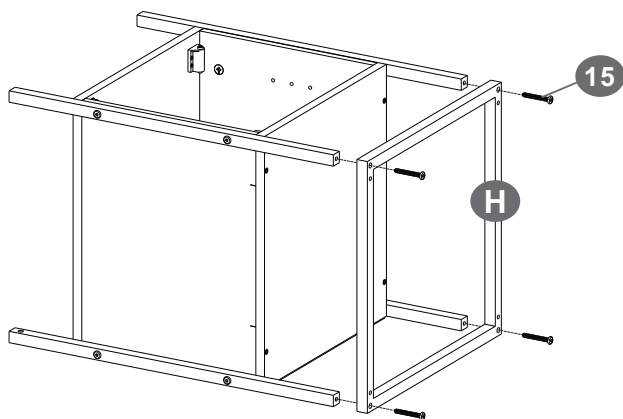

15



4PCS

9

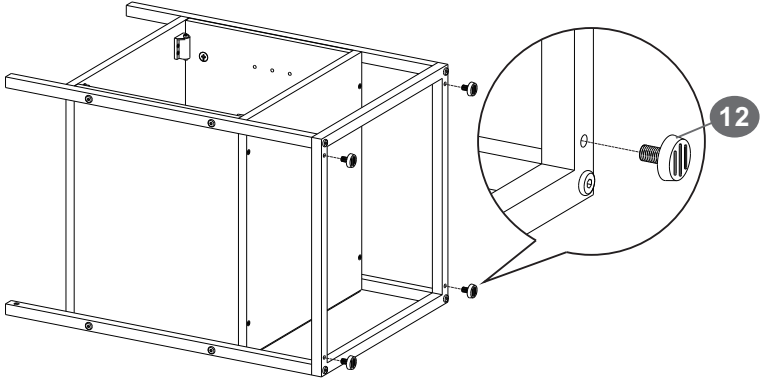

12



4PCS

10

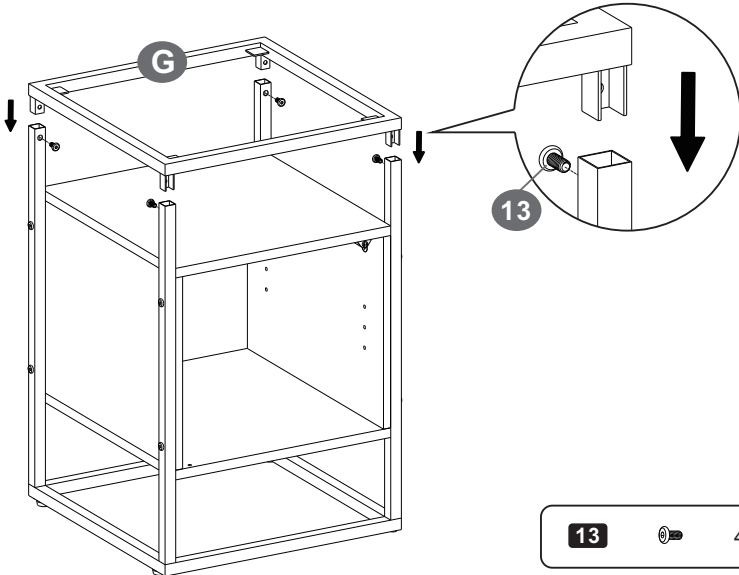



13

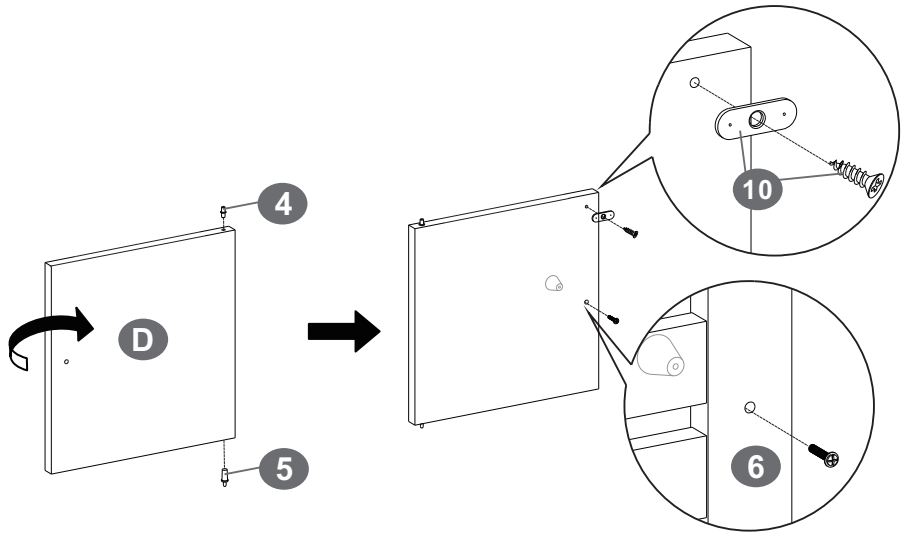

4PCS

11



4		1PC
5		1PC

12

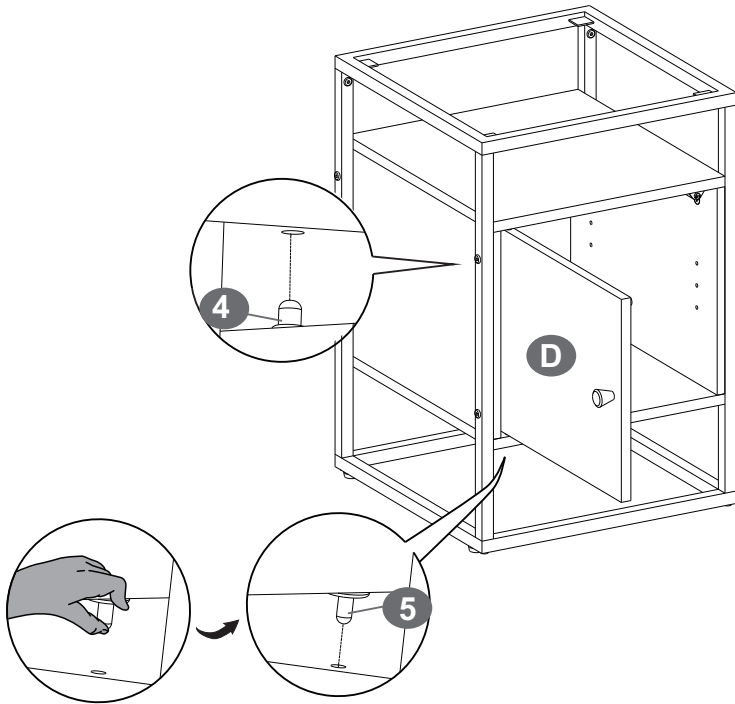

13

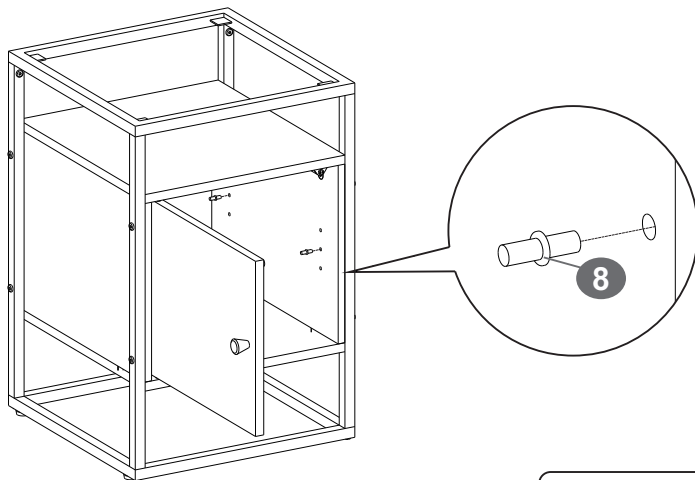

8



4PCS

14

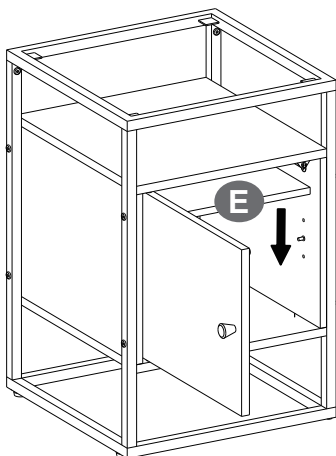

15

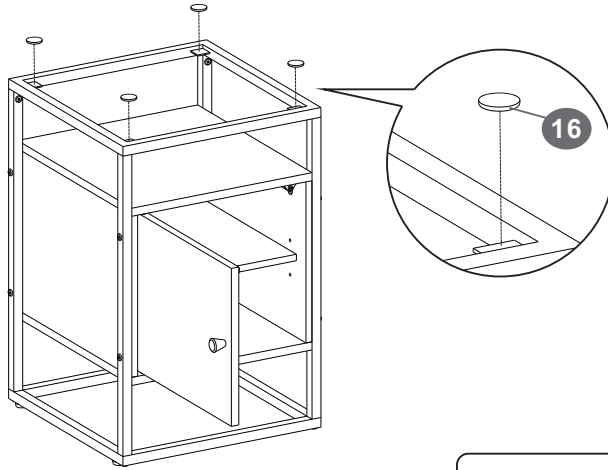

16



4PCS

16

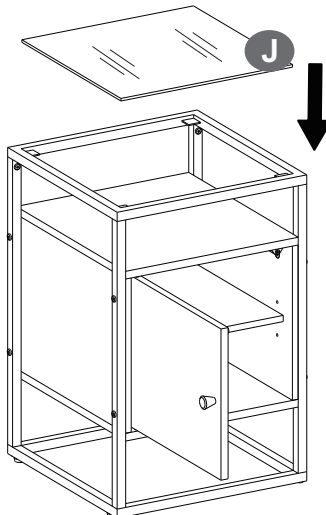

17

